



SOLUTION OVERVIEW

Integrated access to engineering content

Gain a single, unified view of relevant asset information by automatically capturing, relating, and navigating from equipment tags



 **Boost productivity** with fast document search and retrieval capabilities across platforms

 **Ensure compliance and reduce risk** by making all relevant, up-to-date asset information accessible

 **Increase efficiency** with asset navigation

 **Improve master data governance**
Auto validating asset information against master system data

Engineers across industries such as Utilities, Power Generation, Oil & Gas, Mining and Chemicals spend a large amount of time working in CAD drawings, P&IDs and other engineering documents, especially for maintenance and operations tasks.

The challenge is that these documents don't contain all the information required to get a complete view of an asset. Relevant information, such as plant maintenance details or health and safety requirements, are often stored in other systems. This means engineers have to search multiple disparate systems for required content, which can be time consuming and may lead to missing essential data points.

By leveraging Asset Navigation, from Cad-Capture with OpenText™ Extended ECM or OpenText™ Documentum™, engineers benefit from seamless, integrated access to all required asset information from within drawings, regardless of where the information is stored. The automatic activation of asset tags as "HotSpots" provides fast, unified access to drawings and engineering information - even when stored in separate systems. This means engineers get the right version, of the right information, at the right time, to complete their tasks efficiently and effectively.

Capture errors early

Inbound Drawing Verification (IDV) allows drawings, submitted by EPCs, to be checked automatically against existing master data or asset list information accompanying the submission. Errors are highlighted, allowing rejection of drawings, before they are on the critical path of the project, reducing expensive project delays and cost over-runs.

Use case

One of the world's largest independent refiners needed to organize engineering information across the refining circuit to improve response times to events and inquiries and make better informed decisions.

With integrated access to engineering content, the company's engineers can now easily navigate drawings, quickly access related information, and use Hotspots for rapid, intuitive, equipment-based search and retrieval.

By leveraging a shared document repository and consistent user interface, the company has been able to improve knowledge sharing and achieve engineering information integrity.

Boost productivity

Workers can take advantage of fast document search and retrieval capabilities, based on equipment and tag numbers, from within engineering documents. This reduces the time to data, saving time searching for asset content and related documents.

Increase efficiency

Asset Navigation validates and corrects asset information from engineering documents such as P&IDs and operating procedures, turning drawings into automatic information dashboards. It creates/updates a tag library and uploads new tag data into the OpenText content management platform as meta data related to the appropriate content.

This provides a faster and more accurate method of automatically capturing tag data and avoids the human error that can occur when entering tags manually enabling fast and accurate document retrieval.

About Asset Navigation for Energy from OpenText™

Hundreds of Oil & Gas, Utility and Chemical companies across the globe rely on OpenText technology for enterprise content management, remote content collaboration, big data analytics, and artificial intelligence. OpenText provides a fully integrated suite of industry solutions designed to manage the complete engineering content life cycle, from capital project creation through handover and commissioning, to asset operations and maintenance management integration.

To help Energy companies extract, correct, collate, and activate asset tag information from within documentation, Asset Navigation for Energy integrates with [OpenText Extended ECM](#) or [OpenText Documentum](#)

Learn more: cadcap.com/asset-navigation

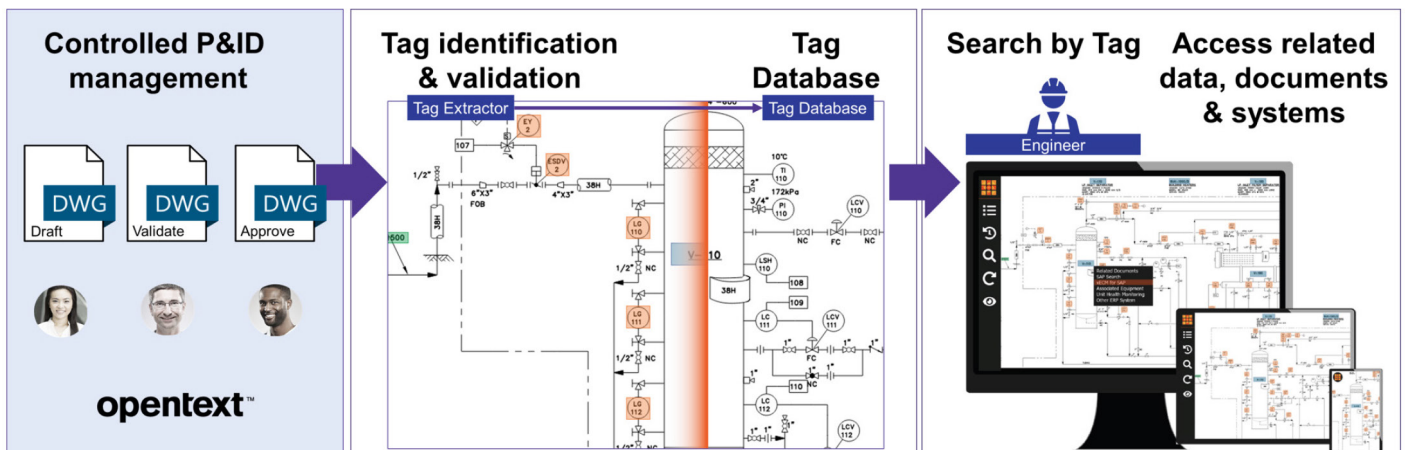

 [Join the conversation](#)

 [Keep up to date](#)

 [Learn more](#)

About OpenText

OpenText, The Information Company, enables organizations to gain insight through market leading information management solutions, on-premises or in the cloud. For more information about OpenText (NASDAQ: OTEX, TSX: OTEX) visit: [opentext.com](https://www.opentext.com).

Connect with us:

- [OpenText CEO Mark Barrenechea's blog](#)
- [X \(formerly Twitter\)](#) | [LinkedIn](#)